



SERVICE MANUAL / PARTS LIST

APPLIANCE CLAMP SOFT TOUCH

MODEL #114450
PATENT NO. 9,630,821
PATENT NO. 10,597,272

CONTENT:

PAGE

1 Lift Truck Requirements
General Installation Procedures
General Inspection & Maintenance

2-3 Clamp Assembly

4 Arm Group Assembly

5-7 Floating Pad Assembly

8-10 Hydraulic Assembly

11 Cylinder Assembly

12 Clamp Adjustments

13 Control Valve

14 Clamp Force Control Valve

15 Arm Slide & Shim Replacement

16 Trouble Shooting Guide

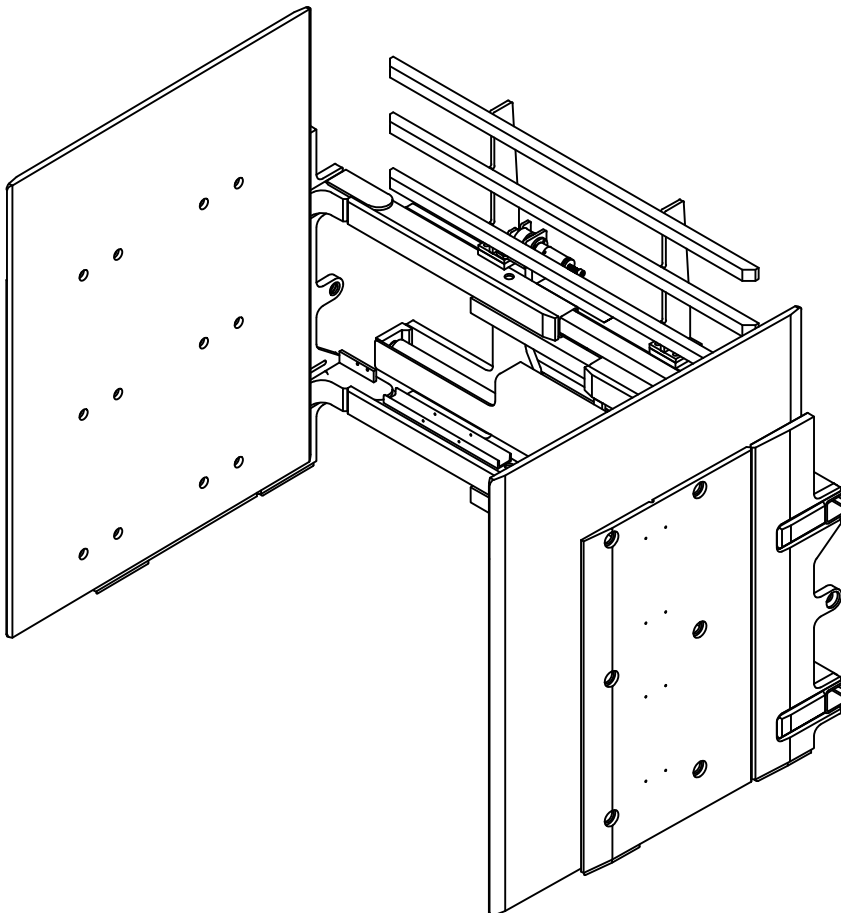

Specifications:

Mounting: Class III
Side Shifting: Internal Side Shifting
Capacity: 2000 lbs at 24"
Pad Size: 60" High x 48" Long
Range: 22.4" - 94.4"
Frame: 59" Wide

425 Hazel St.
Kelso WA 98626
(800) 248-6079
Fax (360) 578-9934

LIFT TRUCK REQUIREMENTS

CAPACITY

Capacity shown on the clamp's name plate is for the clamp only. The combined truck and clamp capacity is provided by the lift truck manufacturer.

CLAMP HYDRAULICS

Recommended Truck Pressure: 2300 to 2400 PSI (159 to 165 bar).

Hydraulic fluid: petroleum based hydraulic fluid only.

Hydraulic supply group: includes hoses and take-up - one for each function.

Auxiliary valves: 2 function (Side Shift & Clamp) = double auxiliary valve.

Oil Volume Settings:

Side Shift = 3 GPM

Clamp Open/Close = 7 GPM

NOTE: Three Position Force Selector must be disabled.

GENERAL INSTALLATION PROCEDURES

1. Make sure that the attachment centering lug is correctly seated in truck carriage center notch.
2. Clearance between the lower retainers that hold the attachment to the truck lower carriage bar should be as shown below.

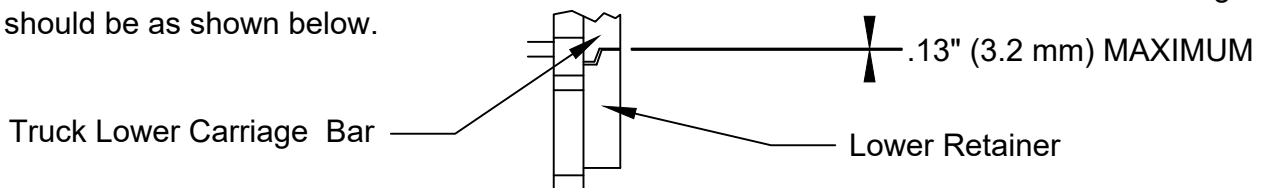

3. Connect hydraulic jumper hoses from the truck's supply group to the attachment's main manifold.
4. Standing clear of the clamp attachment, cycle the attachment in and out several times. Partially filled hydraulic lines may cause erratic movement.

GENERAL INSPECTION AND MAINTENANCE

1. Check all hydraulic fittings, hoses, cylinders and valves for leakages - repair or replace as required.
2. Check bladder system pressure. If out of operating range adjust as required using the LORON hand pump (PN: 112909) and pure propylene glycol antifreeze mixed 1:1 with water. Check clamp force and adjust.

Time Schedule: Check bladder pressure every day and clamp forces every 3 weeks

Bladder System Pressure: 4 - 6 PSI

3. All bolts should be checked and tightened as required.
4. Check lower retainer clearance - see item 2 in the General Installation Procedures above.

CLAMP ASSEMBLY - 1

Drawing Reference: 114435.1

#	QTY	PART #	DESCRIPTION	#	QTY	PART #	DESCRIPTION
1	1	114427	Frame	12	2	111380	Cylinder Rod Washer
2	2	111714.8	Cylinder Assembly	13	2	111112	Lower Retainer
3	1	111652.4	Load Backrest	14	6	11G.1028	Bolt
4	4	114576.1	Flat Slide	15	6	16E.10	Lock Washer
5	8	111621.1	Angle Slide	16	12	111619	Slide Button
6	8	109212.4	Shim	17	1	113853	Cylinder Guard
7	6	1C.0820	Bolt	18	4	25GN.0612	Bolt
8	8	4E.08	Lock Washer	19	4	109528	Nord-Lock Washer
9	4	111631	Spherical Bearing	20	1	114135	Bumper Weldment
10	4	100029.301	Rod Centering Seal	21	2	1CN.0828	Bolt
11	4	100574.83	Cotter Pin				

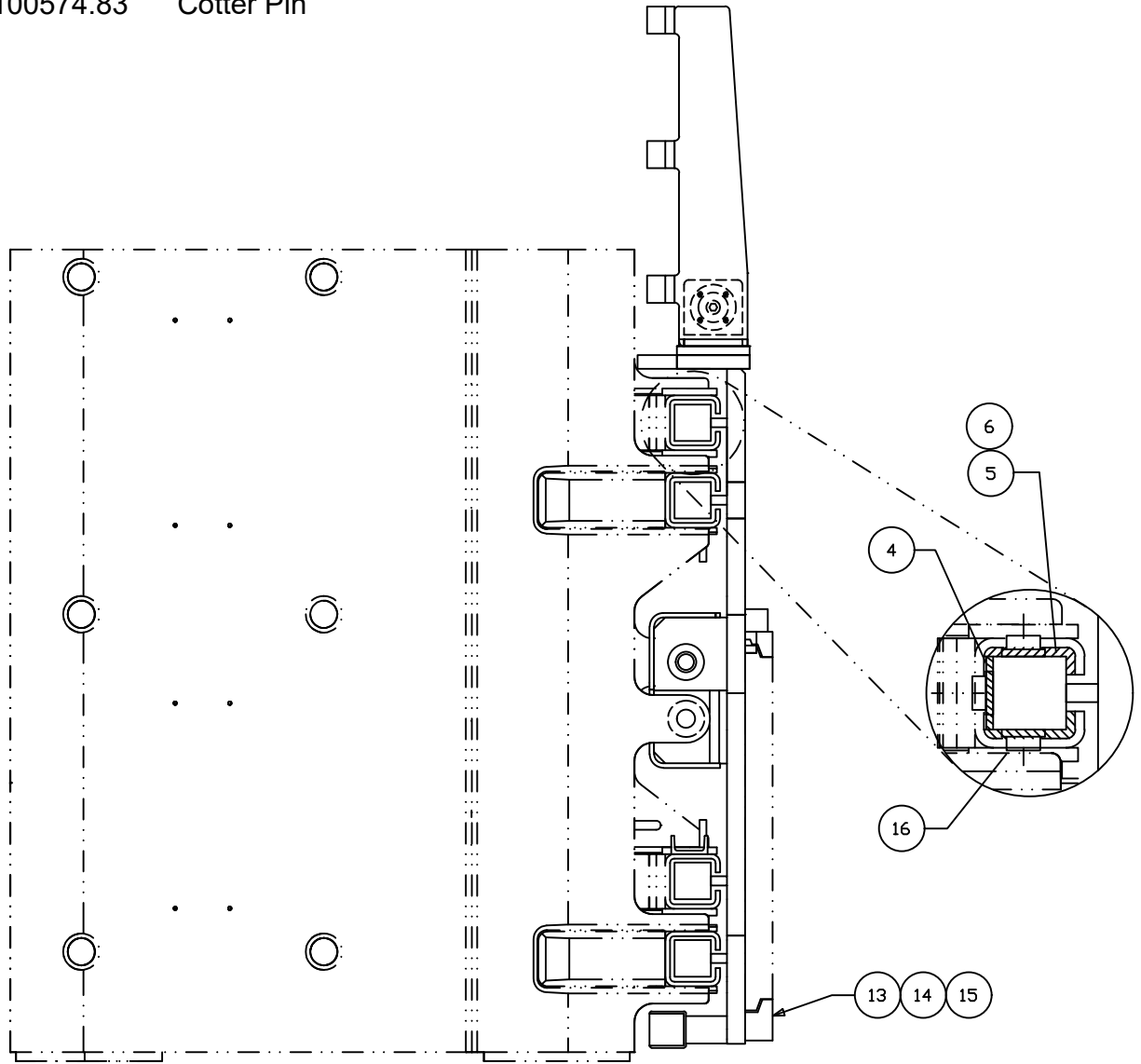

CLAMP ASSEMBLY - 2

Drawing Reference: 114435.1

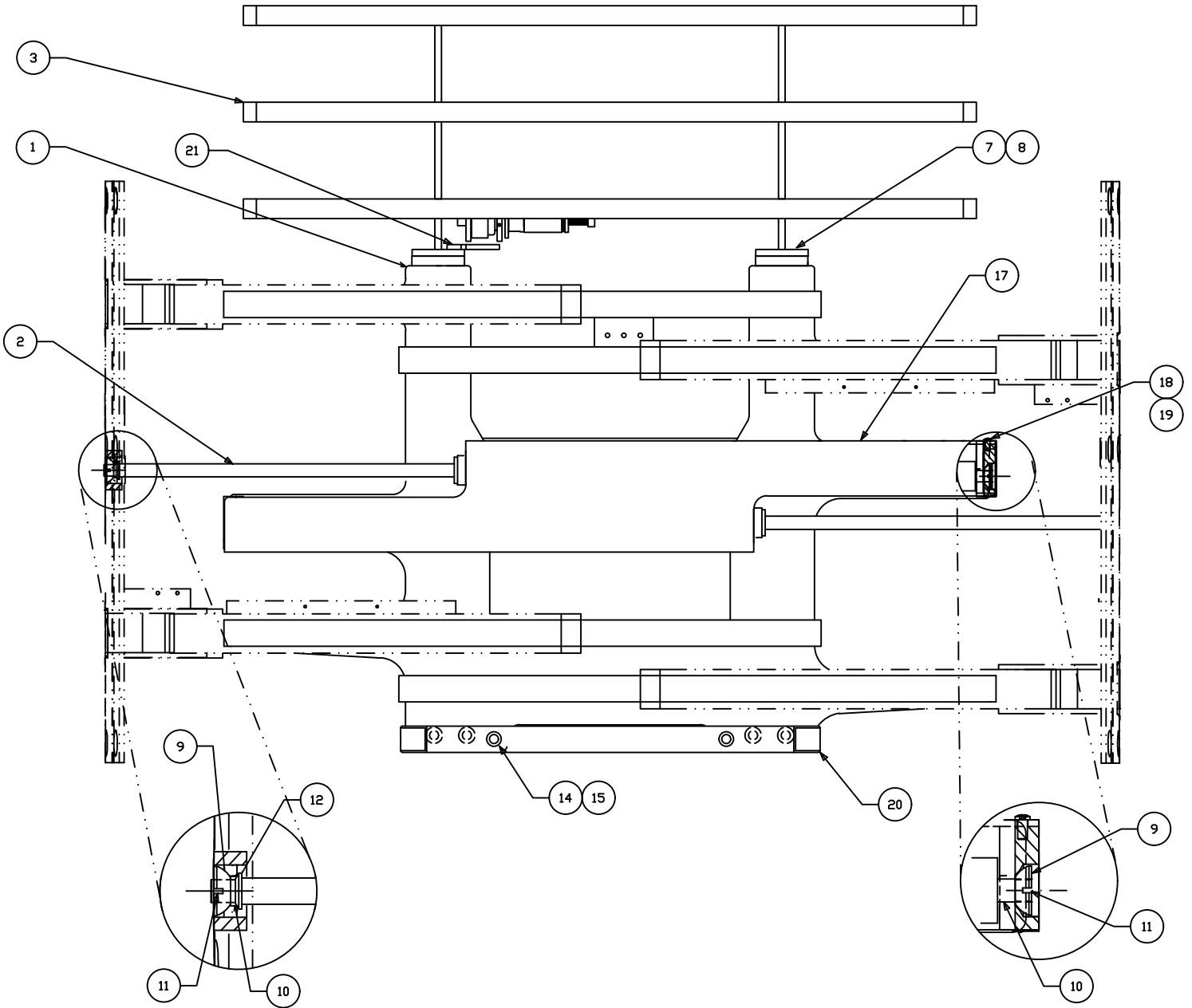

ARM GROUP ASSEMBLY

Drawing Reference: 113700.2

#	QTY	PART #	DESCRIPTION
1	1	113841	Right Hand Arm Weldment
2	1	113844	Left Hand Arm Weldment
3	2	113840	Contact Pad
4	12	111031	Retaining Nut
5	1	113717	Right Hand Tip Plate
6	1	113718	Left Hand Tip Plate
7	12	1C.0820	Bolt
8	6	1C.0812	Bolt
9	18	108088	Spring Washer

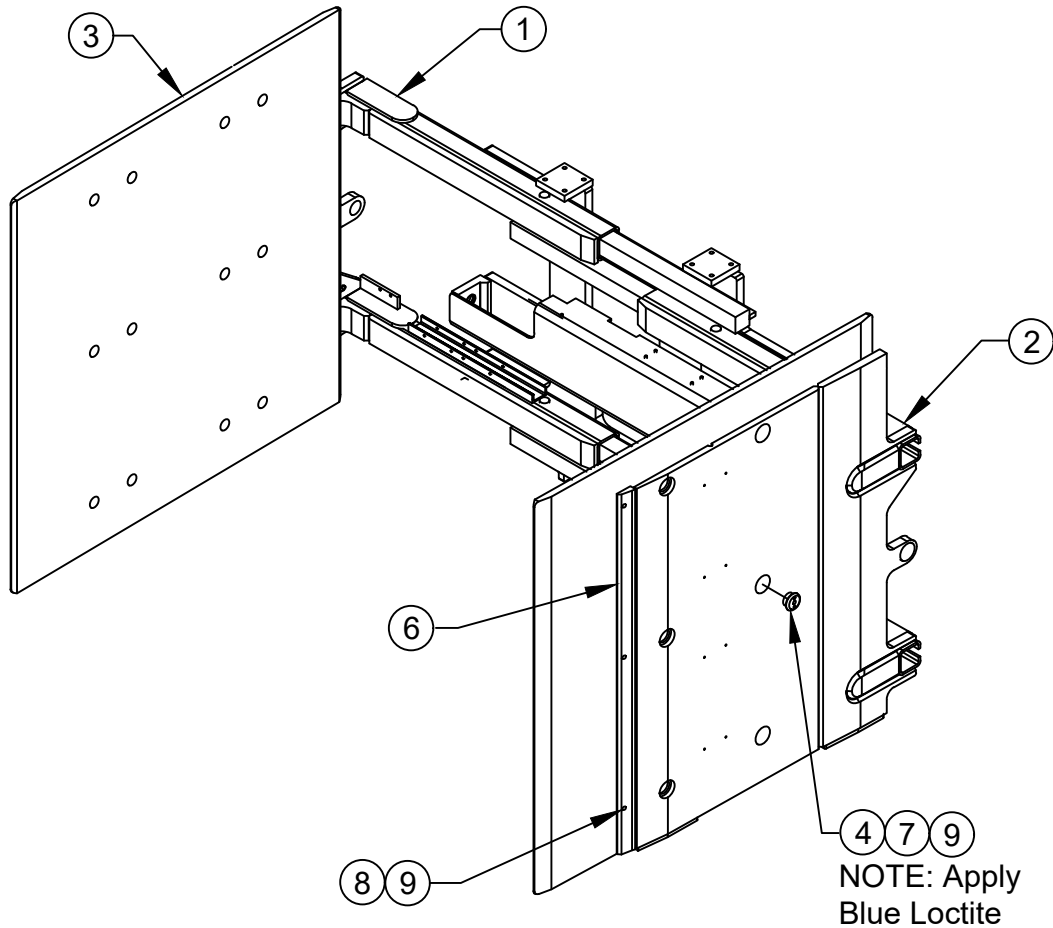

FLOATING PAD ASSEMBLY - 1

Drawing Reference: 113851.1

#	QTY	PART #	DESCRIPTION	#	QTY	PART #	DESCRIPTION
1	3	111350	Air Tank Valve	17	2	113026.0360	Cover Hose
2	9	111295	Hose Clamp	18	2	111290.0116	Hose
3	1	111290.0025	Hose	19	16	9G.0414	Bolt
4	1	111296	Pressure Gauge	20	8	111471	Clamp Bar
5	1	111543.01	90° Elbow Fitting	21	8	109256	Hose Clamp
6	1	111292	Branch Tee	22	8	25GN.0508	Bolt
7	1	111290.0075	Hose	23	4	111128	Hose Guide
8	1	111293	Run Tee	24	12	1C.0512	Bolt
9	1	111290.0057	Hose	25	1	113720	Directional Valve Assy. Ref.
10	1	111290.0240	Hose	26	1	111289	Pipe Elbow
11	1	111290.1205	Hose	27	2	111510	Spring
12	1	111290.1090	Hose	28	16	111878	19 Gauge Wire Tie
13	1	111299	Hose Clip	29	2	113416	Hose Extrusion w/ Holes
14	1	25G.0520	Bolt	30	8	3G.0808	Bolt
15	4	111030	Bladder	31	3	111653	Valve Cap
16	2	111290.0020	Hose	32	1	113970	Wye

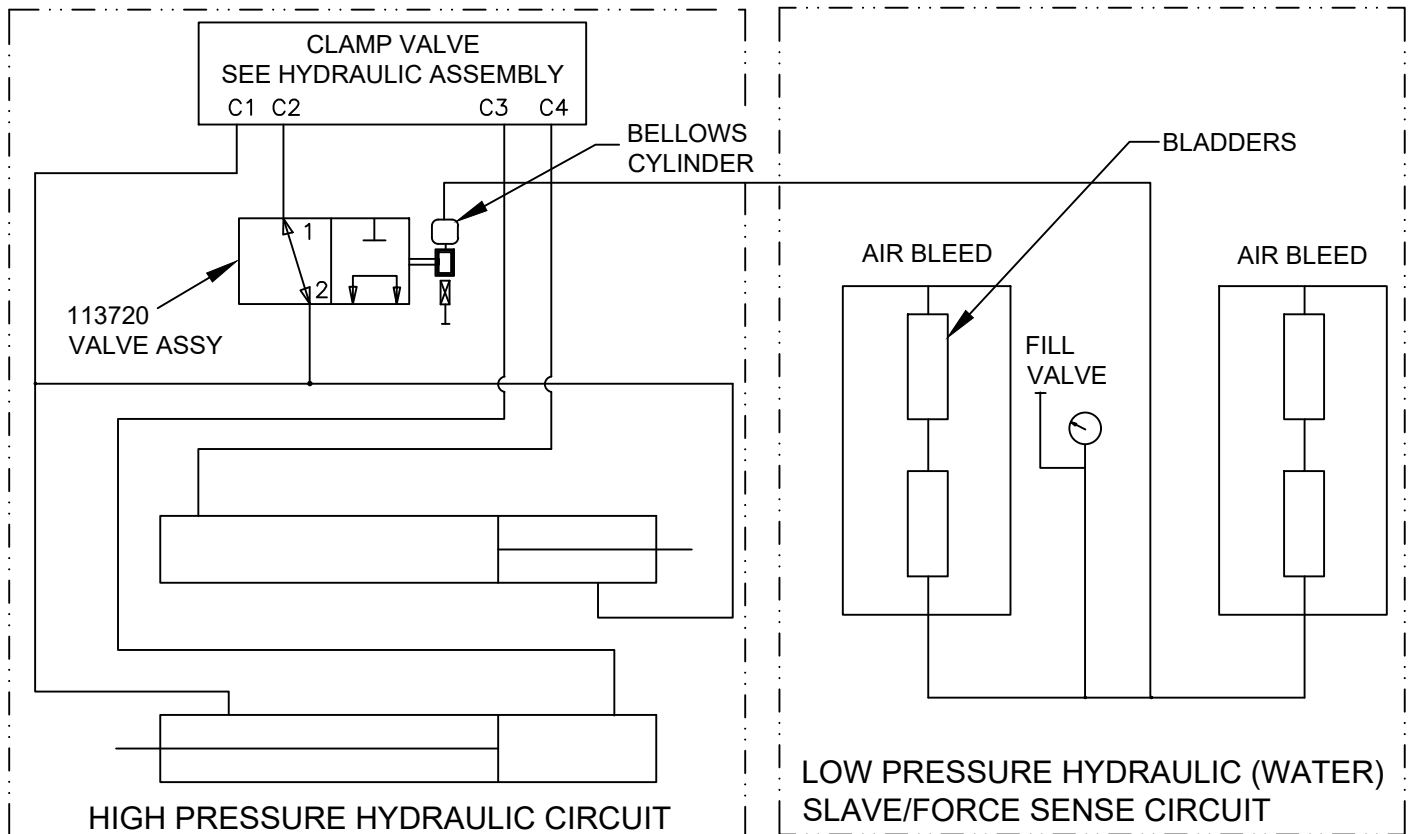

FLOATING PAD ASSEMBLY - 2

Drawing Reference: 113851.1

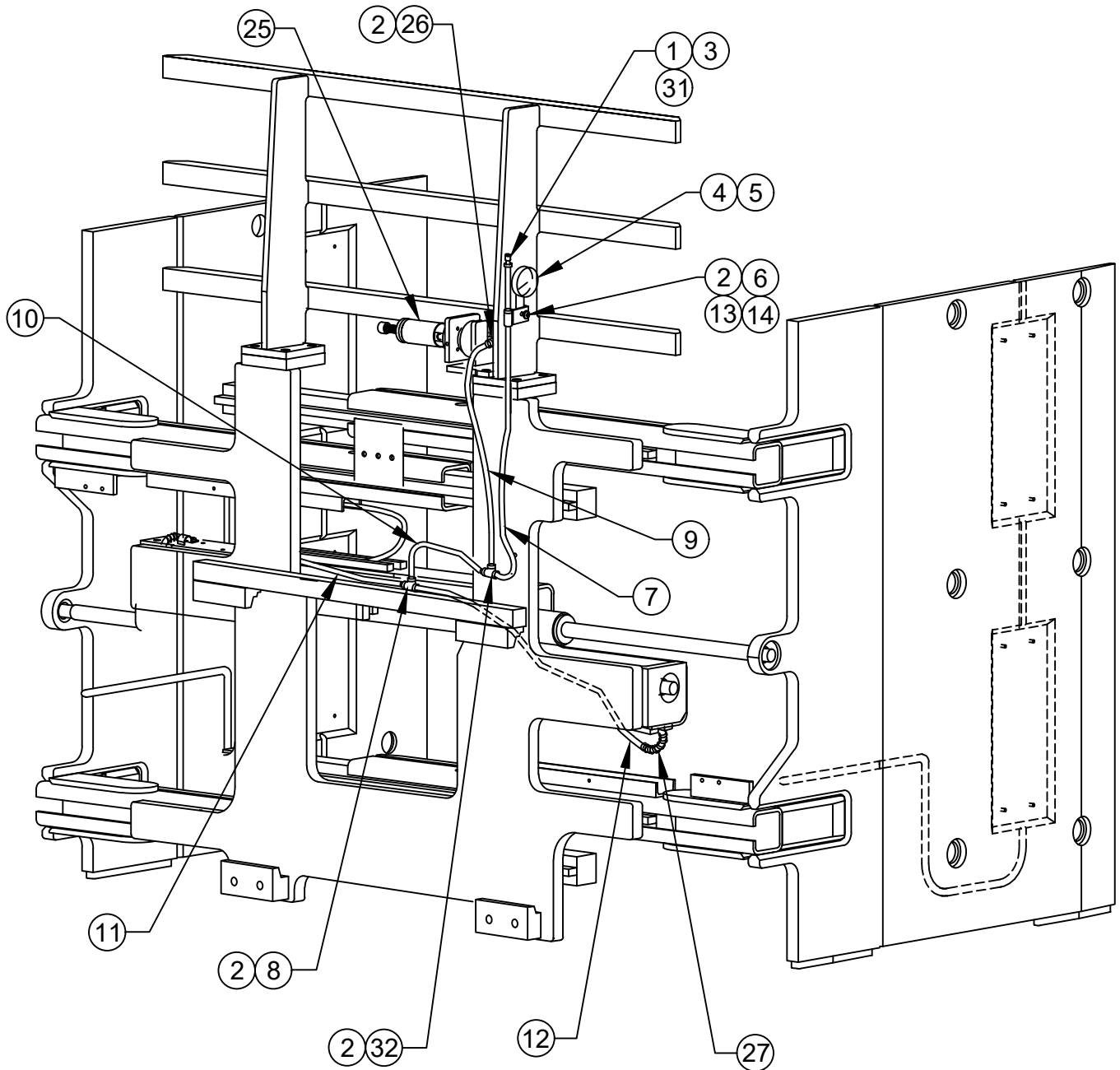

FLOATING PAD ASSEMBLY - 3

Drawing Reference: 113851.1

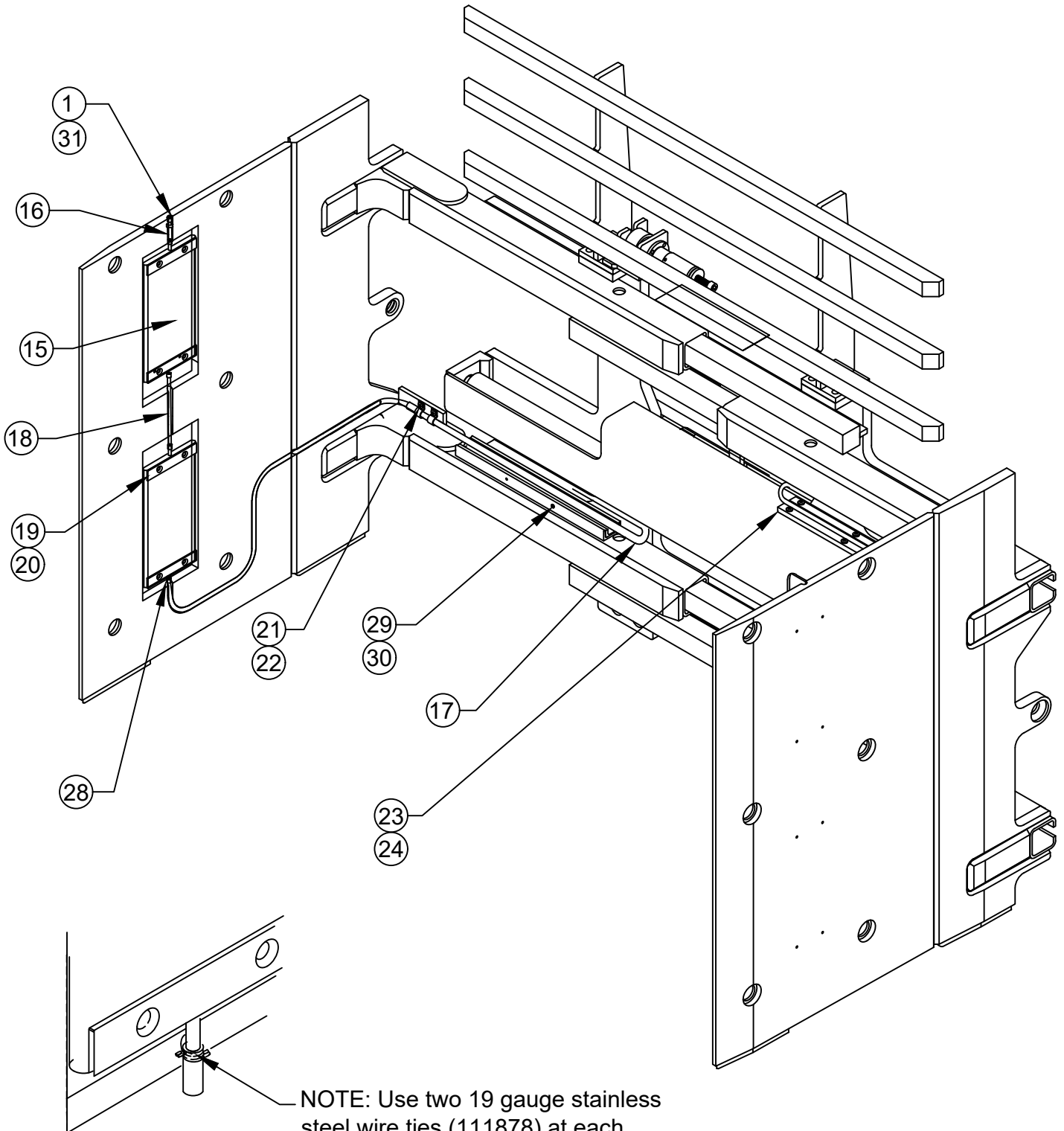

NOTE: Use two 19 gauge stainless steel wire ties (111878) at each bladder connection. Twist to tighten and clip to reduce ends.

HYDRAULIC ASSEMBLY - 1

Drawing Reference: 114421

#	QTY	PART #	DESCRIPTION
1	1	113774	Clamp Valve
2	2	25G.0524	Button HD Bolt
3	6	100676.05	O-Ring Straight Thread Adapter #6-6
4	1	100222	90° O-Ring Restrictor Fitting
5	1	113720	Directional Valve Assembly
6	1	100227.05	Union Tee Fitting
7	1	100674.0053	Hose Assembly
8	1	103411.0225	Hose Assembly
9	1	102702.0193	Hose Assembly
10	1	100678.05	O-Ring Tee Branch Fitting #6
11	4	100440.05	90° Swivel Fitting
12	1	100674.0400	Hose Assembly
13	1	100674.0310	Hose Assembly
14	3	100095.05	90° O-Ring Fitting #6
15	1	102702.0310	Hose Assembly
16	1	100674.0220	Hose Assembly
17	1	113725	Cover
18	2	25G.0412	Button HD Bolt
19	1	100676.03	Straight O-Ring Fitting Adapter
20	1	100238.03	45° Swivel Fitting
21	1	100095.03	90° Fitting #4 O-Ring
22	1	109626.1	O-Ring Straight Restrictor Fitting

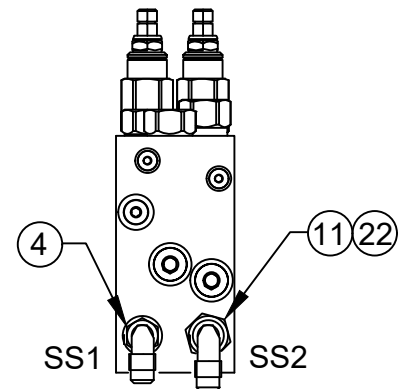
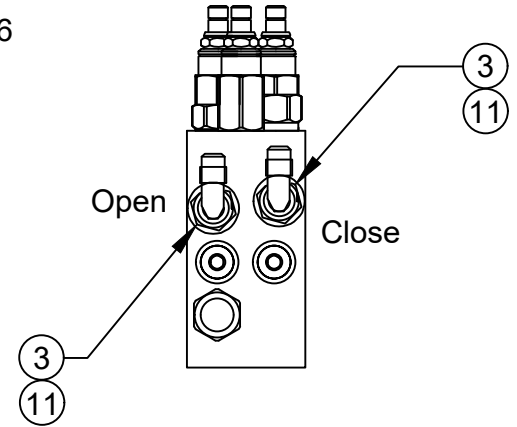

HYDRAULIC ASSEMBLY - 2

Drawing Reference: 114421

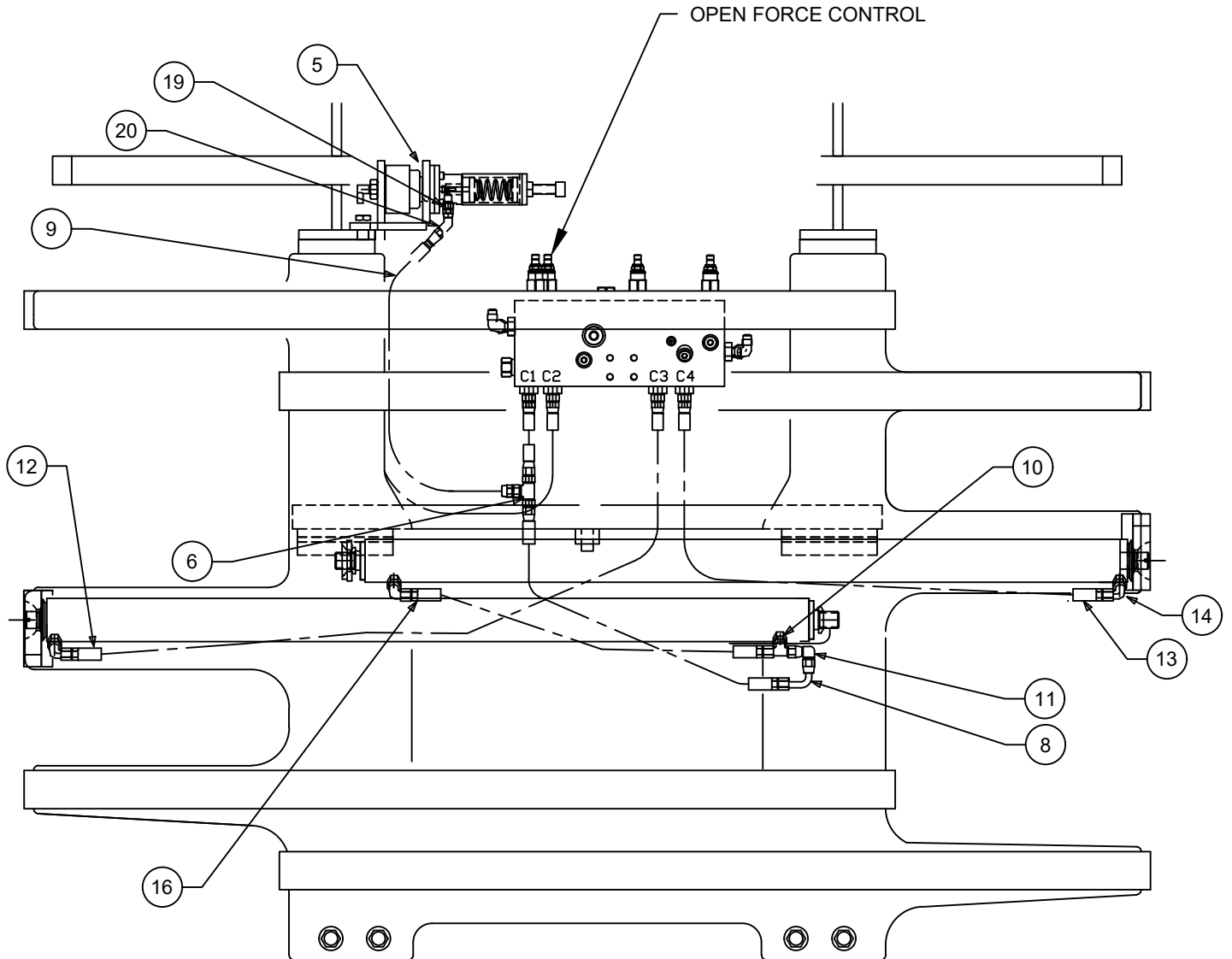

FRONT VIEW

HYDRAULIC ASSEMBLY - 3

Drawing Reference: 114421

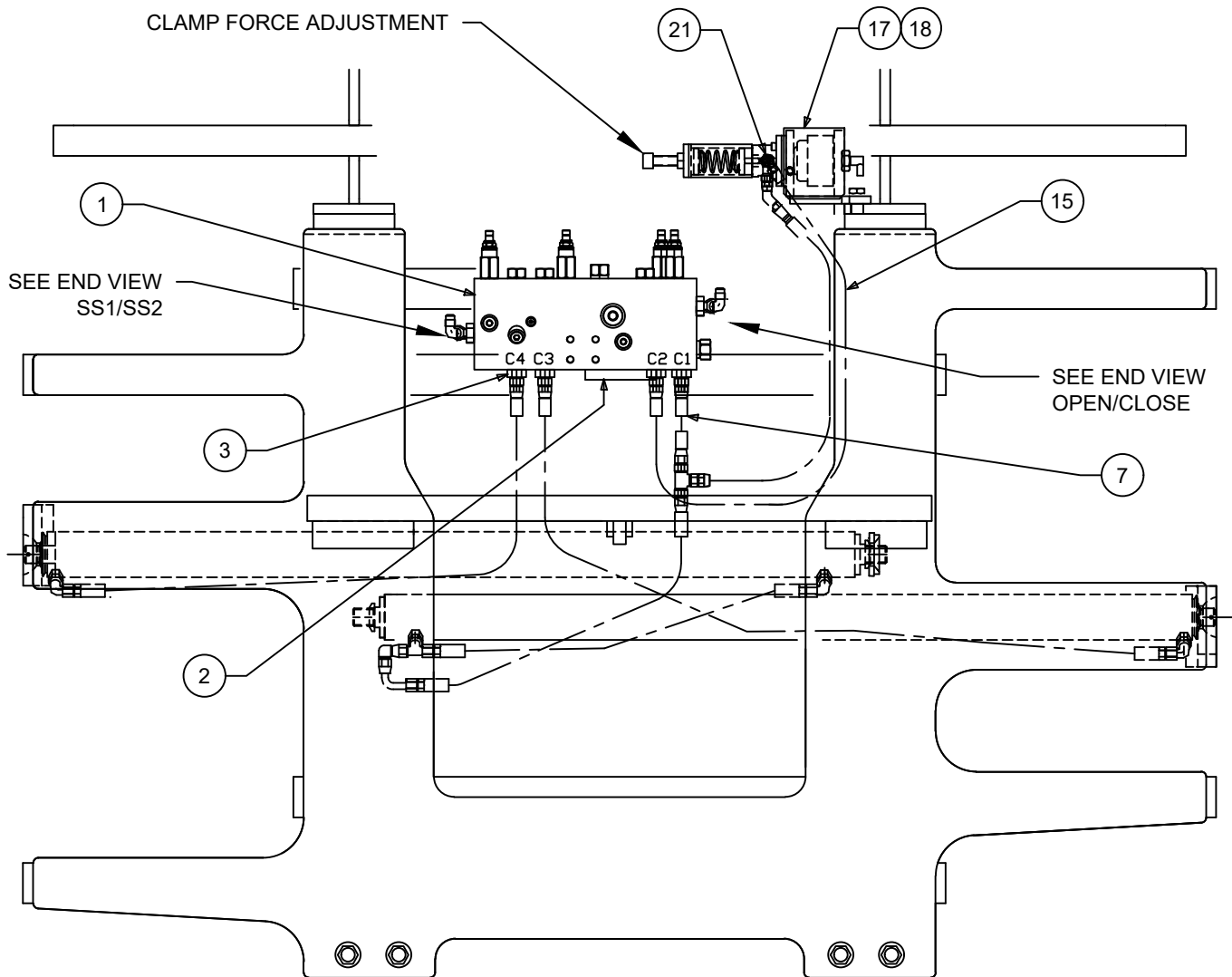

BACK VIEW

CYLINDER ASSEMBLY

Drawing Reference: 111714.8

Part #	R	E	S	NET STROKE
111714.8	40.85	77.70	36.85	36.85

#	QTY	PART #	DESCRIPTION	8	1	100029.2	O-Ring
1	1	111715.7	Tube Weldment	9	1	100028.2	Back-Up Ring
2	1	111717.7	Rod	10	1	100029.201	O-Ring
3	1	111482	Seal Kit (Items 4-10)	11	1	27D.10	Nut Self Locking
4	1	100032.6	Poly-Pak "B"	12	1	100027.7	Lock Wire
5	1	102099.1	Wear Ring	13	1	111374	Piston
6	1	112905	Rod Seal	14	1	111373	Gland
7	1	102098.5	Rod Wiper	15	1	111380	Washer Cylinder (Ref)

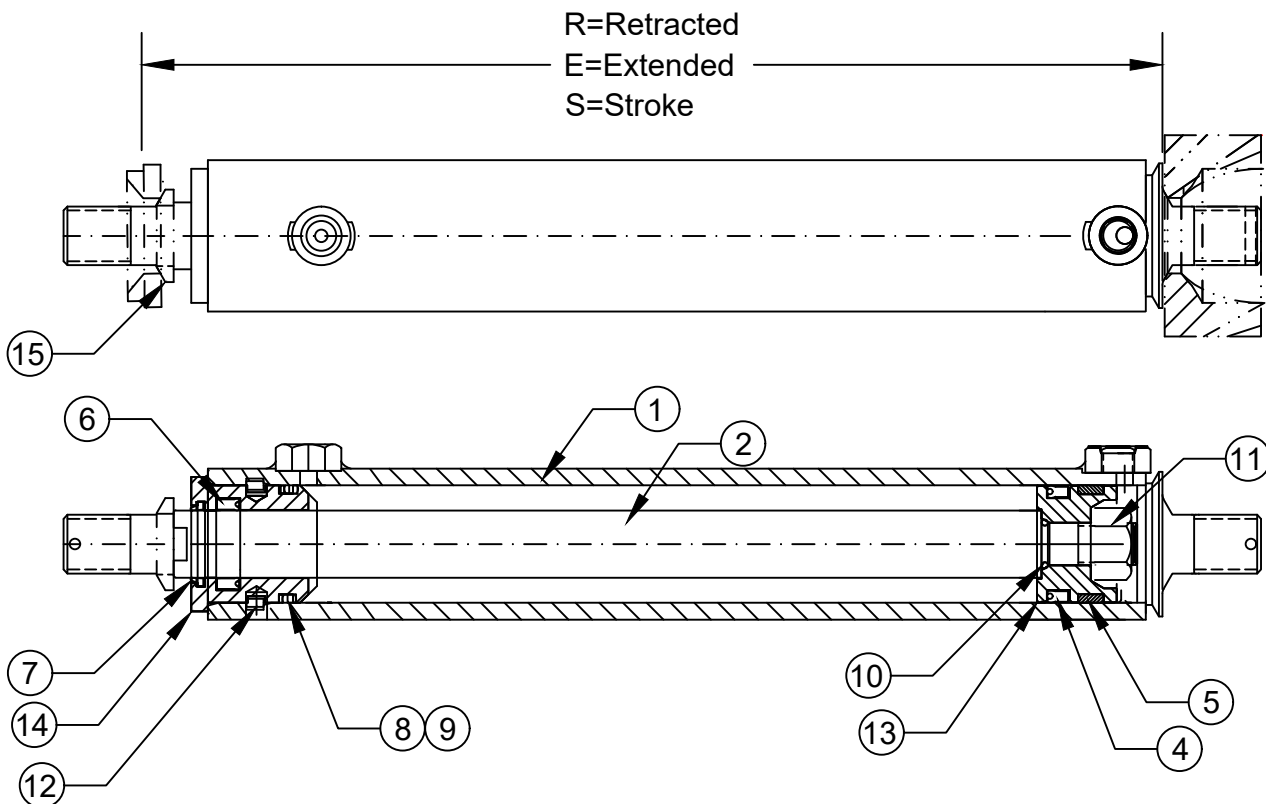

Cylinder Service

- Prior to assembly lubricate seals, cylinder bore and rod with STP.
- Inspect all parts for scratches, nicks and gouges - replace all damaged components.
- Inspect cylinder bore and rod for scoring - replaced if scored.
- Avoid damage to seal grooves - use a dull screwdriver for seal removal.
- Torque piston nut to 110 FT/LBS. (15.3kg-m).

CLAMP ADJUSTMENTS

CLAMP FORCE CHECK/ADJUSTMENT

1. Check water pressure. If out of operating range fill with LORON hand pump # 112909. NOTE: Use pure Propylene Glycol Antifreeze mixed 1 to 1 with water.
2. Check the clamp force. If out of the acceptable force range, adjust with adjustment bolt of the clamp force control valve (see pg 10).

OPEN FORCE CHECK/ADJUSTMENT

Open the arms against a force fixture and adjust for desired maximum force.

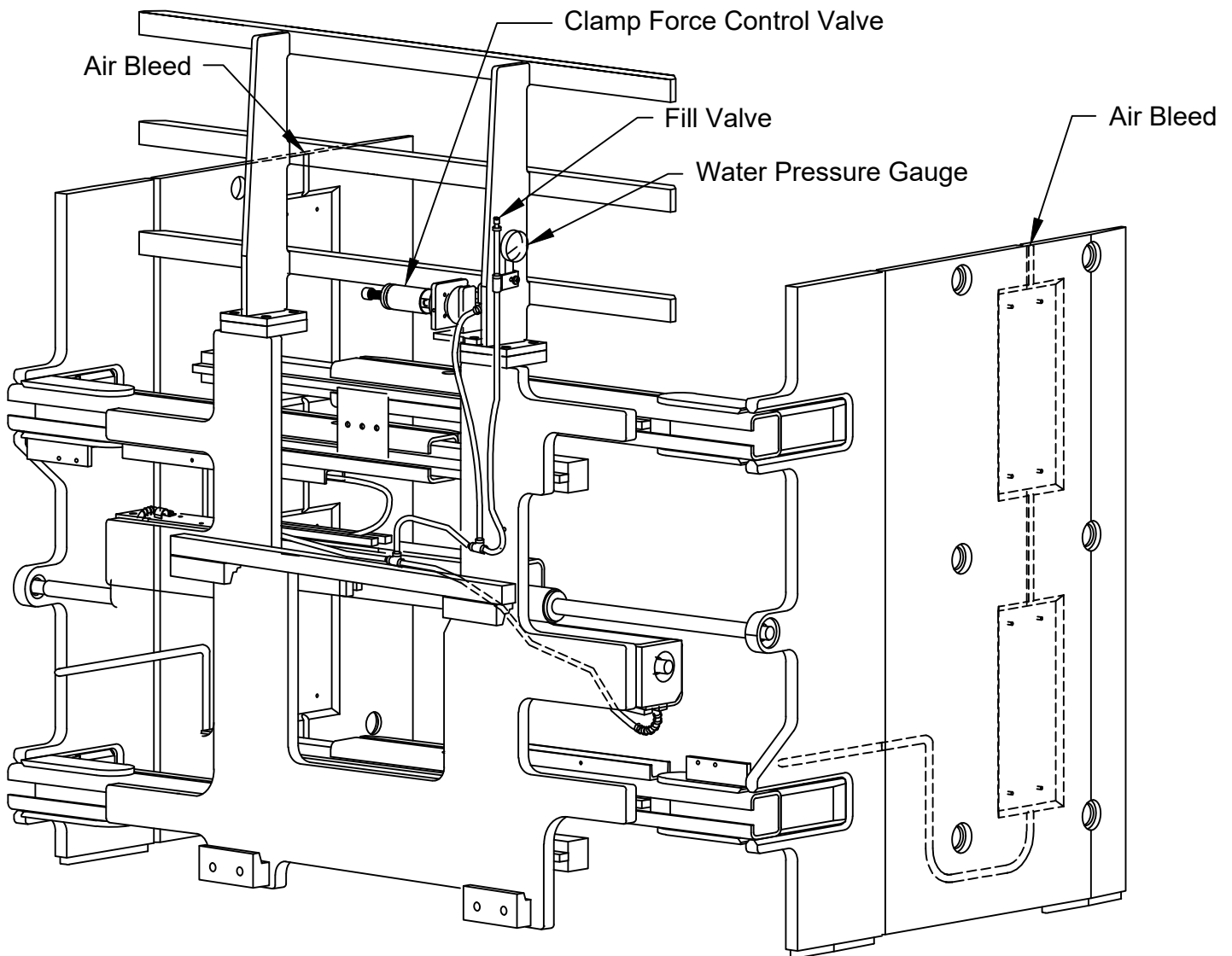

CONTROL VALVE

Drawing Reference: 113774

(A) **113809** Check Valve
 (G) **113983** Check Valve
 Torque 30-35 ft-lb

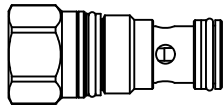

(C) **113806** Flow Divider
 Torque 30-35 ft-lb

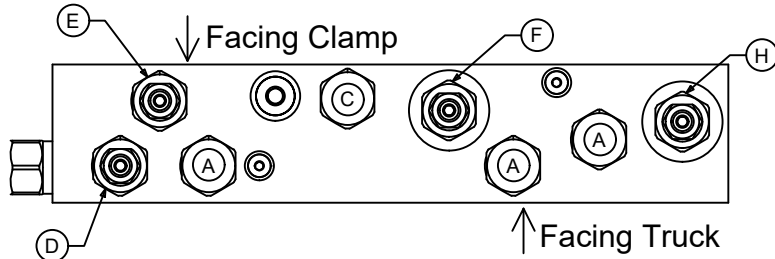
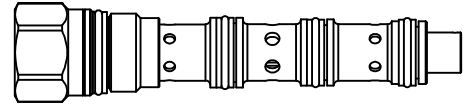

(D) & (E) **113807** Pressure Reducing/Relieving Valve
 Torque 30-35 ft-lb

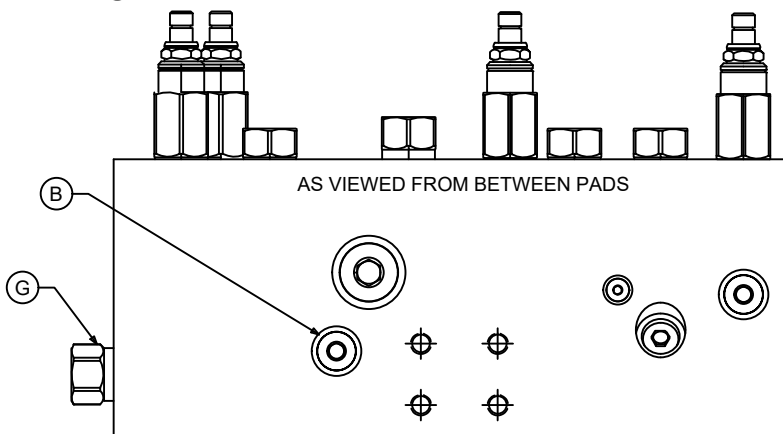
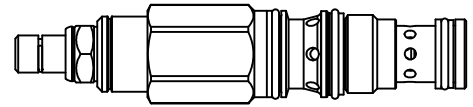

(F) & (H) **113810** Bi-Directional Relief Valve
 Torque 25-30 ft-lb

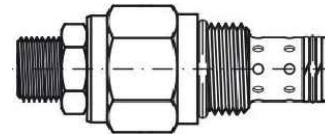

NOTE: Lubricate threads & seals prior to assembly.

ID	QTY	PART #	DESCRIPTION
A	3	113809	P/O Check Valve
B	1	0.031 ORIFICE	1/8" NPT Orifice Plug
C	1	113806	Flow Divider-Combiner
D	1	113807	Pressure Reducing Valve (Close)
E	1	113807	Pressure Reducing Valve (Open)
F	1	113810	Bi-Directional Relief (Flow Divider)
G	1	113983	Check Valve
H	1	113810	Bi-Directional Relief (Side Shift)

HYDRAULIC SCHEMATIC

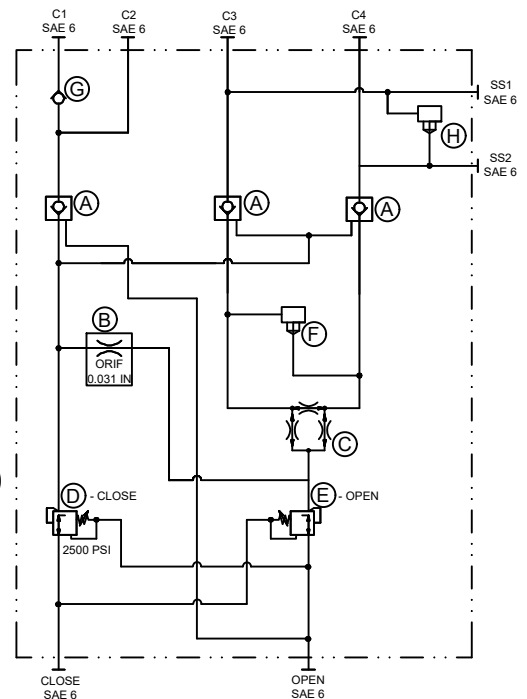

CLAMP FORCE CONTROL VALVE

Drawing Reference: 113720

#	QTY	PART #	DESCRIPTION
1	1	113721	Mounting Plate Weldment
2	1	111091	Air Spring
3	1	THA 7160	Tube
4	1	1C.0514	Bolt
5	1	113680	Spacer
6	4	11G.0414	Bolt
7	1	113779	Control Valve Assembly
8	1	7D.10	Jam Nut
9	1	103488.5	Bearing

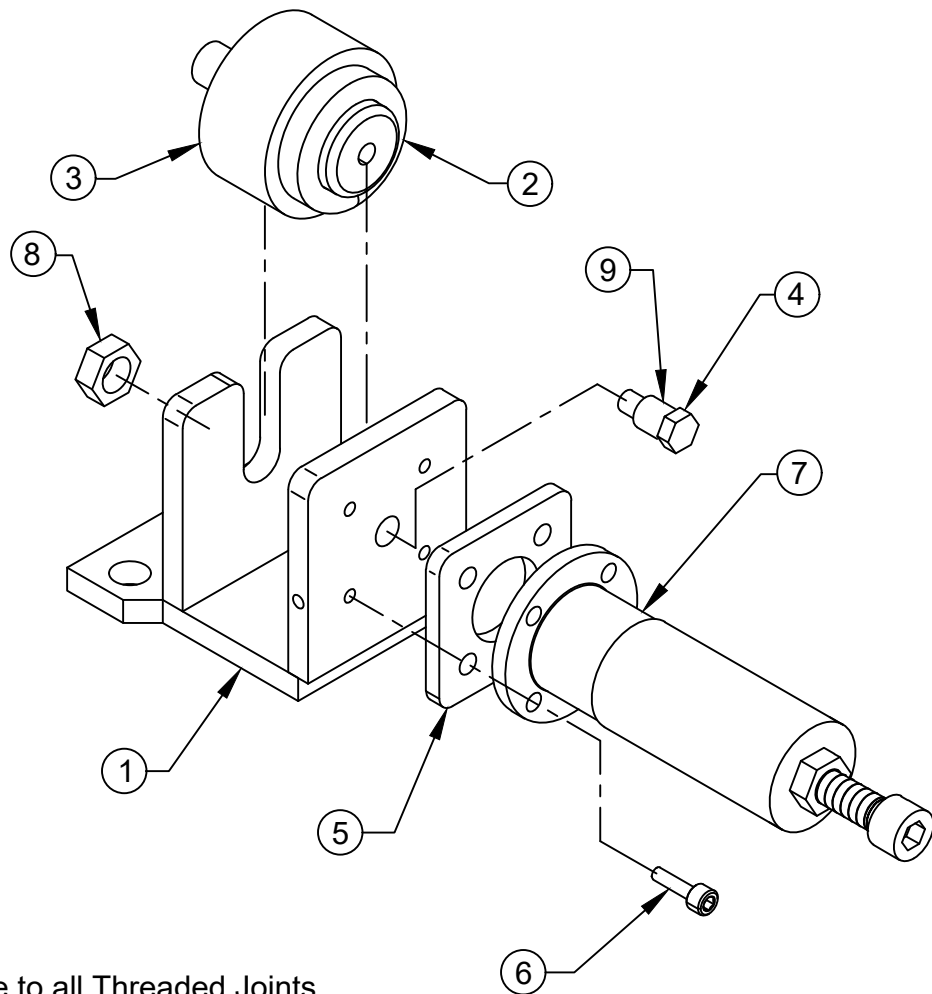

Note: Apply Loctite to all Threaded Joints

ARM SLIDE & SHIM REPLACEMENT

1. To replace the slides, the arms need to be in the fully open position. Release system pressure prior to removing the arms by turning the truck off and working the side shift and clamp function controls several times.
2. Support the arm with an overhead crane or lift truck. Be sure to secure the chain or sling in a manner that prevents the arm from falling out of the chain or sling when hanging free of the clamp.
3. Remove the cotter pin, slotted nut and spherical bearing from the end of the clamp cylinder rod. Keeping hands and feet clear, and carefully slide the clamp arm off of the clamp frame.
4. Inspect slides and slide buttons for wear. Slides may be rotated end-to-end and reused if excessively worn on the outer end only. Extra shims may be used to tighten operating clearance on slightly worn slides. Replace any slides worn to less than 0.15" (3.8mm) thick or any slide that is deeply scored or broken.

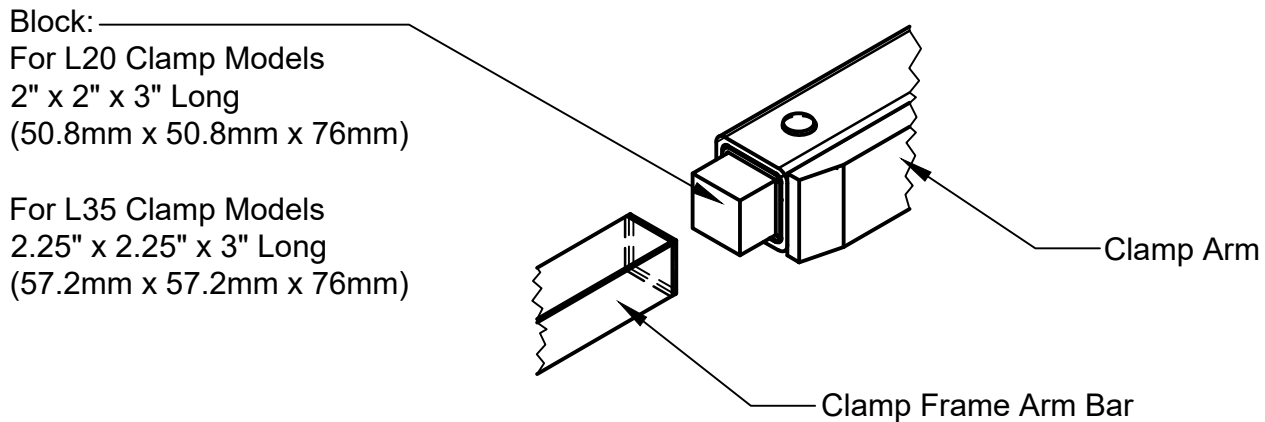

5. To aid in replacing the slides a block may be fashioned of wood or another convenient material to the dimensions shown above. The block is inserted to the end of the arm to hold the slides, shims, and buttons in position while the arm is inserted over the arm bars on the clamp frame. The block is expelled out the opposite end of the arm as the arm is pushed onto the frame. Prior to installing the arm the block may be used to determine the number of shims to place under the slides. Adjust the clearance between the slides and the block to provide approximately .06" (1.5mm) running clearance between the slides and arm when installed.
6. Keeping hands and feet clear, carefully slide the clamp arm onto the clamp frame. Be sure the arm moves freely without excessive binding. If the arm is too loose or too tight add or remove shims as required.
7. Install the spherical bearing, slotted nut and cotter pin onto the end of the clamp cylinder rod. Be sure to leave .03"-.06" (.7mm to 1.5mm) clearance to allow the cylinder to "float" on its mountings.

TROUBLE SHOOTING GUIDE

LOADS SLIPPING OR DROPPING

POSSIBLE CAUSES

SOLUTION

- | | |
|--|--|
| 1. Clamp force set too low. | 1. Adjust clamp force. |
| 2. Internal leakage in cylinder. | 2. Replace cylinder seals. If tube, pistons or rod is scored replace with new parts. |
| 3. Load too heavy for the clamp capacity. | 3. Consult factory. |
| 4. Load may not be stacked correctly or may need to be unitized. | 4. Restack or unitize load (shrink wrap). |
| 5. Bent arms or contact pads. | 5. Consult factory. |
| 6. Damaged / leaking hydraulic hose | 6. Replace damaged hose. |

CRUSHING LOADS

POSSIBLE CAUSES

SOLUTION

- | | |
|--------------------------------|--------------------------------|
| 1. Clamp force set too high. | 1. Adjust clamp force. |
| 2. Bent arms or contact pads. | 2. Consult factory. |
| 3. Leak in the bladder system. | 3. Check for leaks and repair. |

ARM CHATTERING OR ERRATIC MOVEMENT

POSSIBLE CAUSES

SOLUTION

- | | |
|---|--|
| 1. Bent clamp arms. | 1. Consult factory. |
| 2. Nylon slides sticking.
Note: Sticking slides can cause inconsistent force measurements. | 2. Clean slides if necessary, the slides are self lubricating. |
| 3. Nylon slides worn, broken or missing. | 3. Replace damaged slides, shims, and retaining buttons. |