

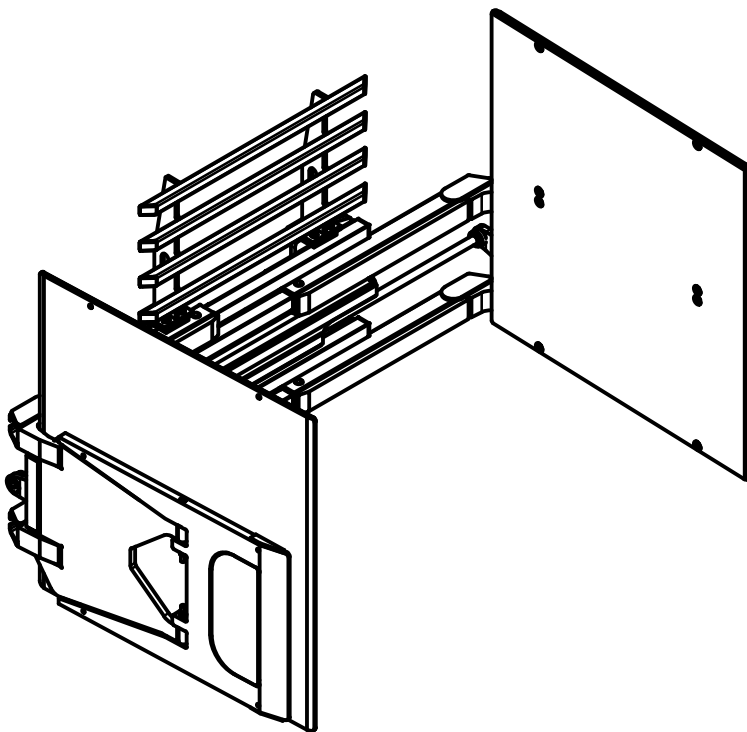

# SERVICE MANUAL / PARTS LIST

## CARTON CLAMP

MODEL #107802



## CONTENT:

### PAGE

1	Lift Truck Requirements General Installation Procedures General Inspection & Maintenance
2-4	Clamp Assembly
5	Hydraulic Assembly
6	Cylinder Assembly
7	Clamp Control Valve
8	Adjusting Relief Valve Adjusting System Pressure Adjusting By-Pass Pressure
9	Slide and Shim Replacement
10	Trouble Shooting Guide

### Specifications:

Mounting: Class II

Capacity: 3500 lbs at 24"

Pad Size: 54" High x 54" Long

Range: 22" - 88"

Frame: 54" Wide

R1 - 11/2023

425 Hazel St.  
Kelso WA 98626  
(800) 248-6079  
Fax (360) 578-9934

---

---

# LIFT TRUCK REQUIREMENTS

---

## CAPACITY

Capacity shown on the clamp's name plate is for the clamp only. The combined truck and clamp capacity is provided by the lift truck manufacturer.

## CLAMP HYDRAULICS

**Recommended Truck Pressure:** 1700 PSI (142 to 170 bar)

**Oil volume:** 6-10 GPM (22.5 to 38 l/min)

**Hydraulic fluid:** petroleum based hydraulic fluid only

**Hydraulic supply group:** includes hoses and take-up - one set for each function

**Auxiliary valves:**

2 Function (Side Shift & Clamp) = double auxiliary valve

---

---

## GENERAL INSTALLATION PROCEDURES

---

1. Make sure the attachment's centering lug is correctly seated in truck carriage center notch.
2. Clearance between the lower retainers that hold the attachment to the truck's lower carriage bar should be as shown below.

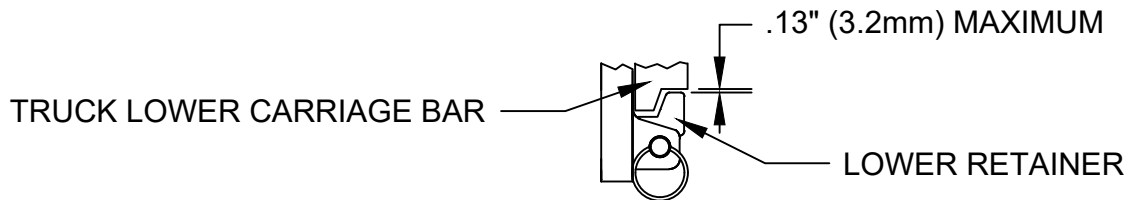

3. Connect hydraulic jumper hoses from the truck's supply group to the attachment's main manifold.
4. Standing clear of the clamp attachment, cycle the attachment open and close several times to distribute the hydraulic oil. Use caution because partially filled hydraulic lines may cause erratic movement.

---

---

## GENERAL INSPECTION AND MAINTENANCE

---

1. Check all hydraulic fittings, hoses, cylinders and valves for leakage. Repair or replace as required.
2. Check hoses for pinch points and signs of wear. Replace worn hoses with LORON hose or Parker Parflex # 560 wire (reinforced hose only).
3. All bolts should be checked and tightened as required.
4. Check lower retainer clearance referenced in item 2 of the General Installation Procedures above. A shim may be tack-welded to the bottom of the lower retainers to tighten the clearance if necessary.

---

---

# CLAMP ASSEMBLY - 1

---

Drawing Reference: 103706.8

---

#	QTY	PART #	DESCRIPTION
1	1	101043.15	Frame Weldment
2	2	101744.5	Pad
3	1	101446.6	Right Hand Arm
4	1	100988.6	Left Hand Arm
5	2	101068.38	Cylinder Assembly
6	1	101448.14	Load Backrest
7	1	101635.7	Cover
8	8	103660.22	Angle Slide
9	4	100047	Cylinder Washer
10	4	101324	Spherical Bearing
11	4	101333	Slotted Nut
12	4	100574.83	Cotter Pin
13	4	11G.08136	Bolt
14	4	17D.08	ESNA Nut
15	2	101680.7	Pad Support
16	8	1C.0820	Bolt
17	8	108088	Spring Washer
18	2	101098	Lower Hook
19	2	100077.3	Round Bar
20	2	100572.060	Ball Lock Pin
21	2	11G.0612	Bolt
22	2	16E.06	Lock Washer
23	12	107997	Slide Button
24	2	25G.0612	Bolt
25	2	4E.06	Lock Washer
26	8	25G.0824	Bolt
27	8	4E.08	Lock Washer
28	12	109653.2	Arm Shim
29	4	103661.22	Flat Slide

# CLAMP ASSEMBLY - 2

Drawing Reference: 103706.8

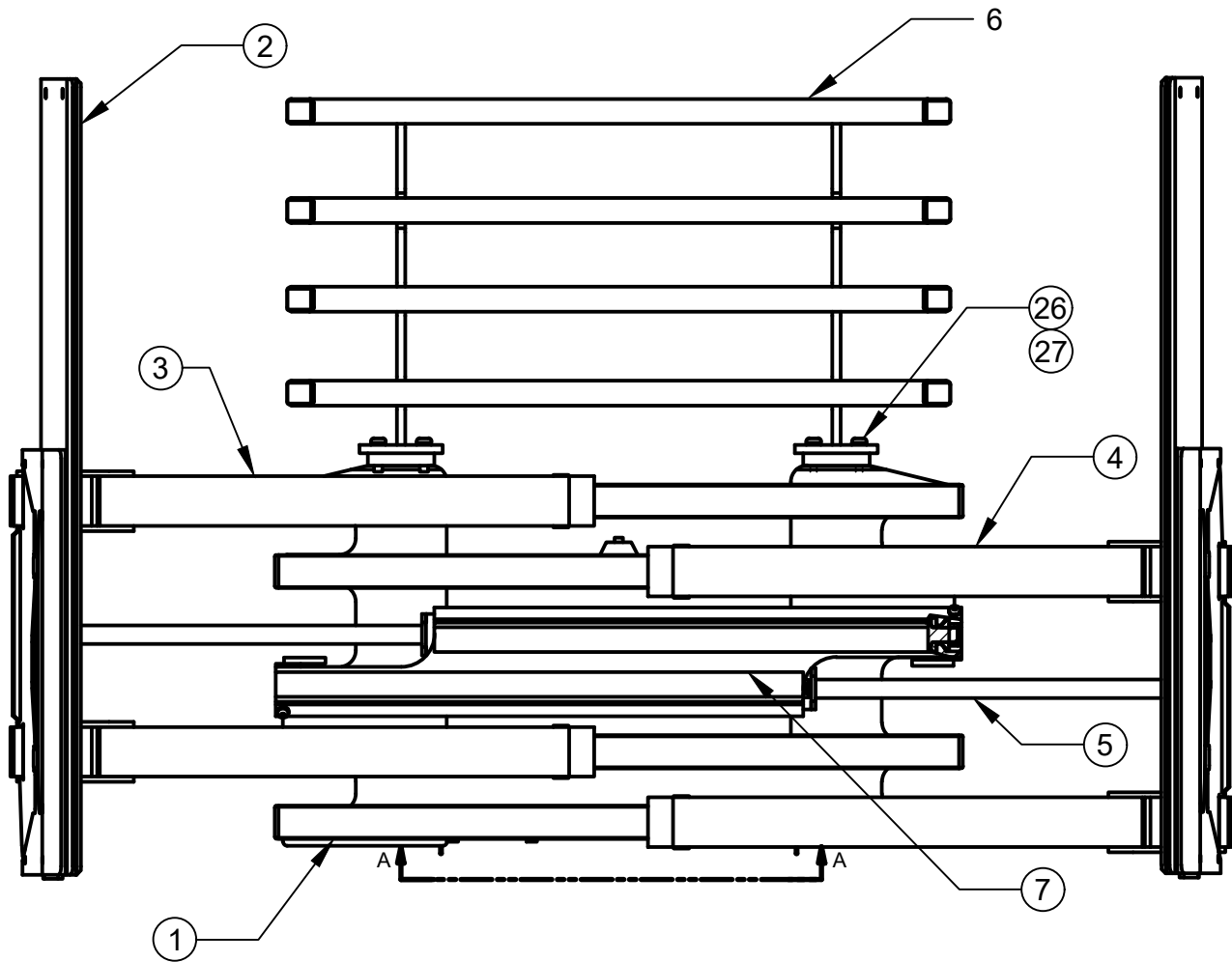

VIEW A-A

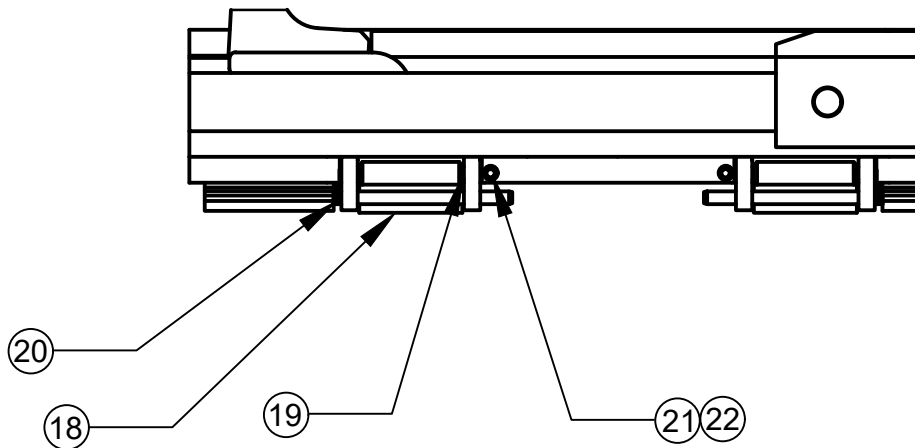

# CLAMP ASSEMBLY - 3

Drawing Reference: 103706.8

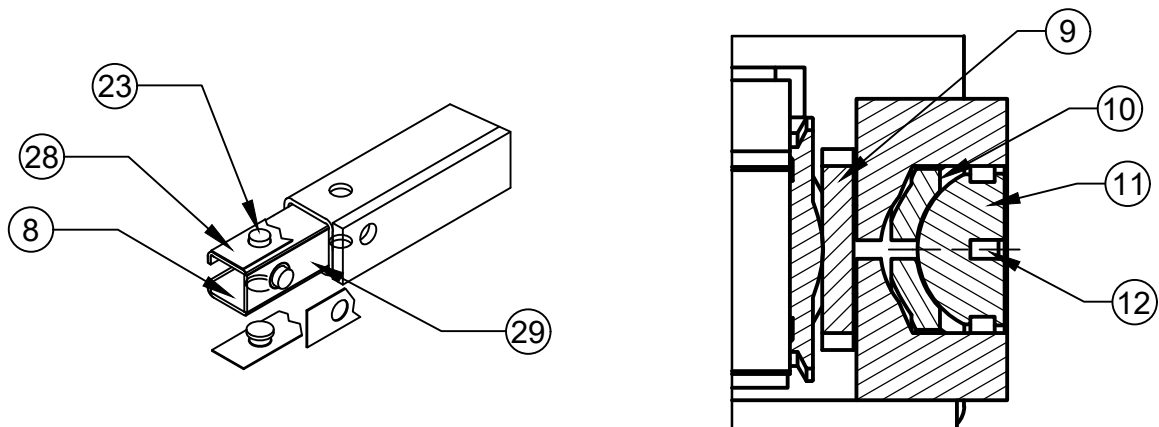
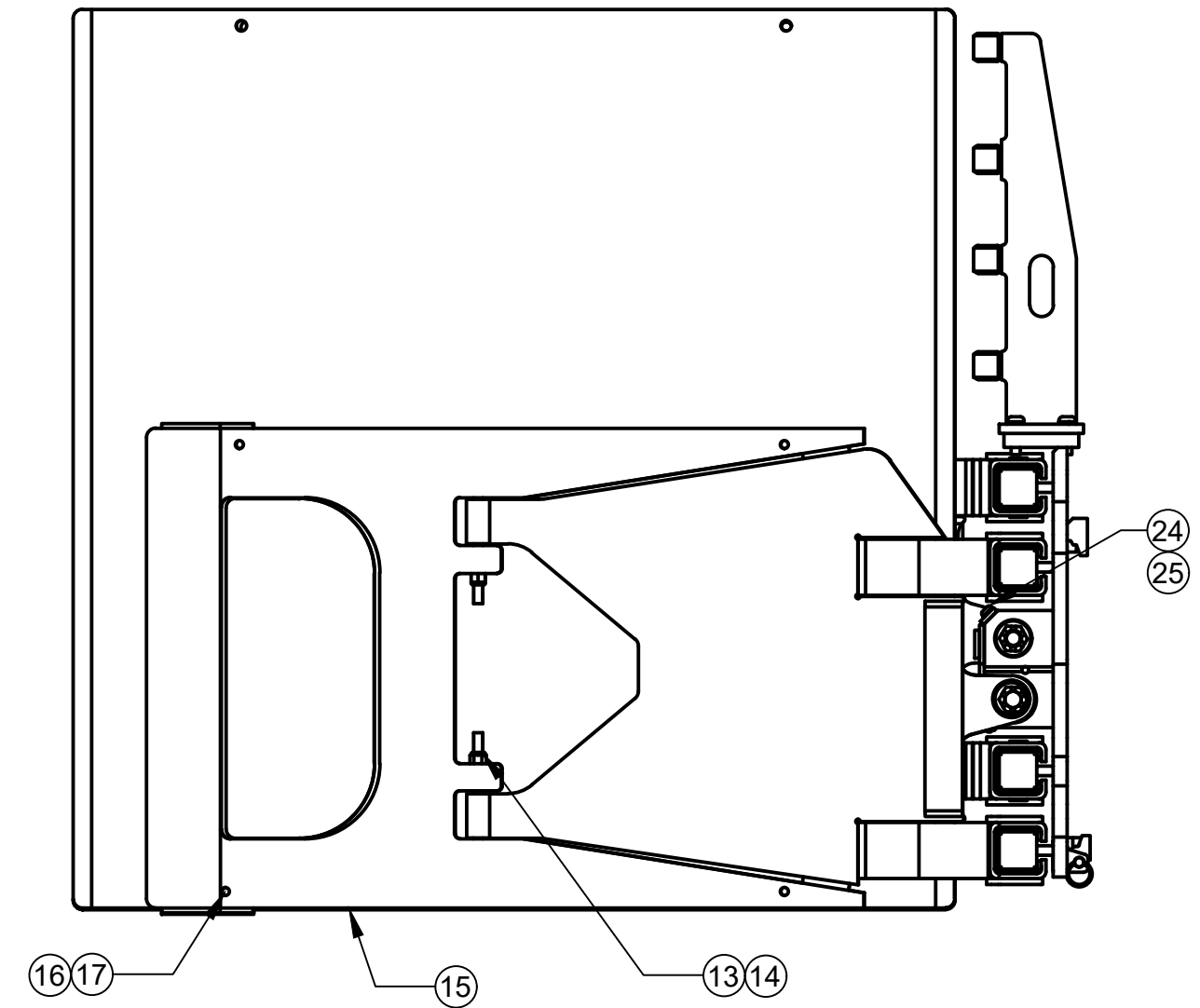

# HYDRAULIC ASSEMBLY

Drawing Reference: 101125.16

#	QTY	PART #	DESCRIPTION
1	1	100674.0265	Hose
2	1	100674.0330	Hose
3	1	100674.0190	Hose
4	1	100674.0145	Hose
5	1	101423	Mounting Plate
6	1	100011	Main Clamp Manifold
7	2	25GN.0516	Bolt
8	4	100095.05	90° O-Ring Fitting
9	8	100676.05	Straight O-Ring Adapter

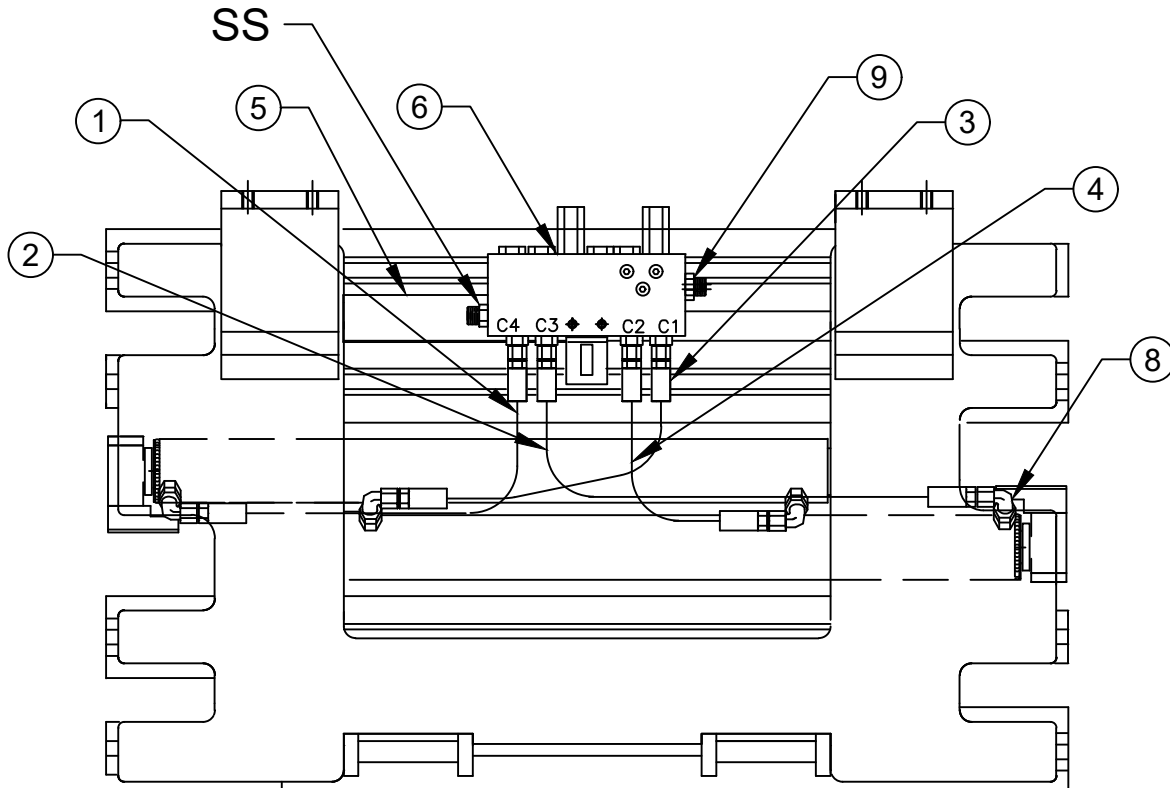
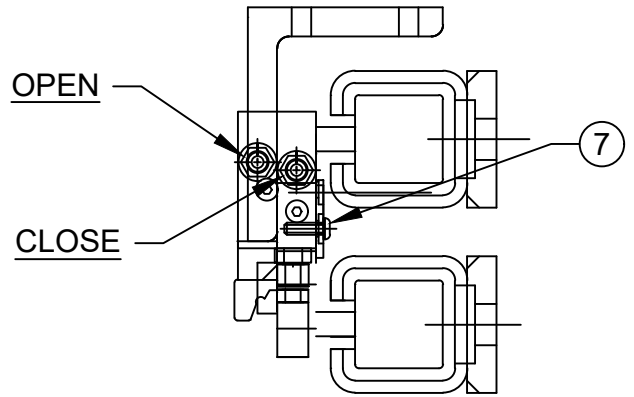

AS VEIWed FROM DRIVERS SEAT

# CYLINDER ASSEMBLY

Drawing Reference: 101068.38

Part #	R	E	S	NET STROKE
101068.38	38.13	71.63	33.50	33.50

#	QTY	PART #	DESCRIPTION	#	QTY	PART #	DESCRIPTION
1	1	101069.36	Tube Weldment	8	1	100031.059	Poly Pak
2	1	100965.71	Rod	9	1	100028.316	Back-Up Ring
3	1	100021	Piston	10	1	100029.316	O-Ring
4	1	100020	Gland	11	1	100033	Wear Ring
5	1	101036	Seal Kit (Items 6-14)	12	1	101034.6	Wiper
6	1	101035	ESNA Nut	13	1	100027.1	Lock Wire
7	1	100032.107	Poly Pak	14	1	100029.203	O-Ring

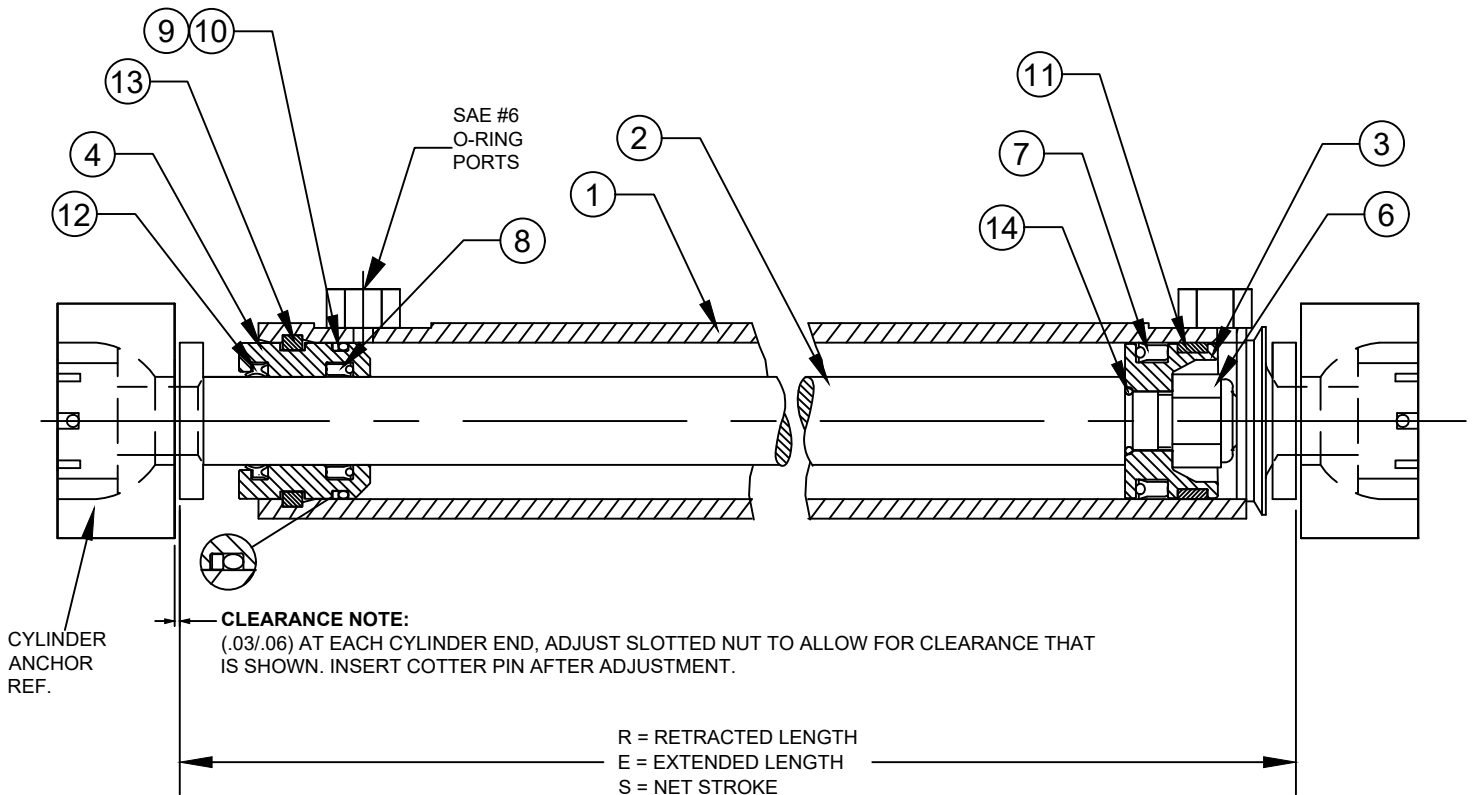

## Cylinder Service

- Prior to assembly lubricate seals, cylinder bore and rod with STP.
- Inspect all parts for scratches, nicks and gouges - replace all damaged components.
- Inspect cylinder bore and rod for scoring - replace if scored.
- Avoid damage to seal grooves - use a dull screwdriver for seal removal.
- Torque piston nut to 200 FT-LBS. (27.7kg-m).

# CLAMP CONTROL VALVE

Drawing Reference: 100011

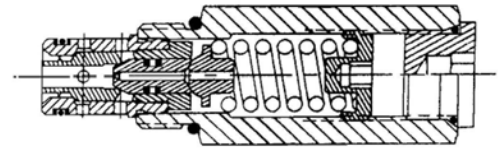
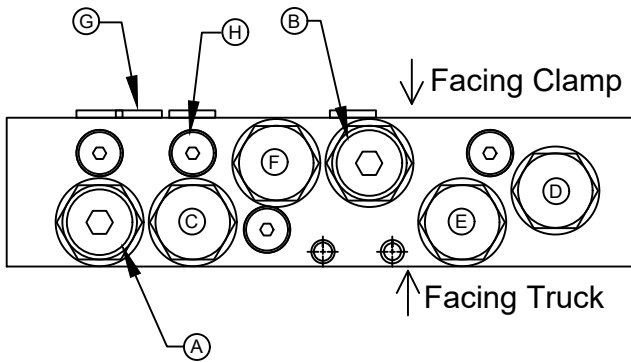

(B) 103815 BIDIRECTIONAL RELIEF  
 (A) 103815.1 BIDIRECTIONAL RELIEF  
 TORQUE TO 35-40 FT/LBS  
 104716 SEAL KIT

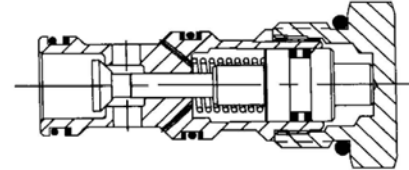

(C, D, E) 103814 P.O. CHECK VALVE  
 TORQUE 35-40 FT/LBS  
 104715 SEAL KIT

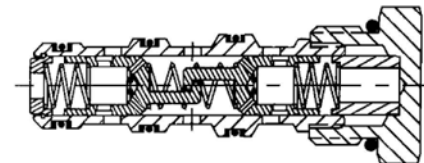

(F) 103813 FLOW DIVIDER  
 TORQUE 10-12 FT/LBS  
 104711 SEAL KIT

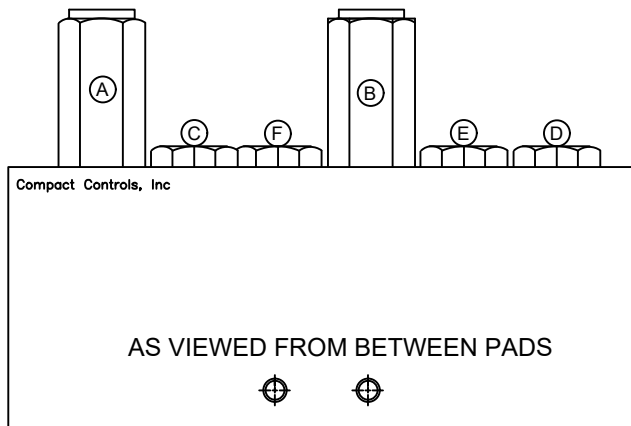

**NOTE:**

Lubricate threads & seals prior to assembly.  
 Side Shifting Ports plugged for Non-Side Shift

ID	QTY	PART #	DESCRIPTION
A	1	103815.1	Bi-Directional Relief Cartridge
B	1	103815	Bi-Directional Relief Cartridge
C	1	103814	P.O. Check Valve Cartridge
D	1	103814	P.O. Check Valve Cartridge
E	1	103814	P.O. Check Valve Cartridge
F	1	103813	Flow Divider Cartridge
G	1	104721	Orifice
H	14	101419.03	SAE #4 O-Ring Plug

## HYDRAULIC SCHEMATIC

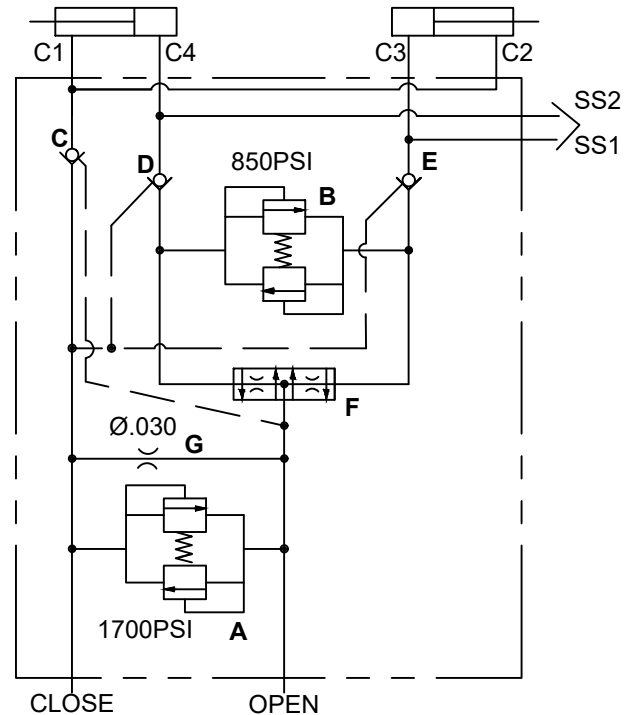



---

---

## ADJUSTING RELIEF VALVE

---

---

### **WARNING:**

RELEASE TRUCK PRESSURE PRIOR TO SERVICING VALVE BY TURNING THE TRUCK OFF AND "WORKING" THE SIDE SHIFT AND CLAMP FUNCTION CONTROLS.

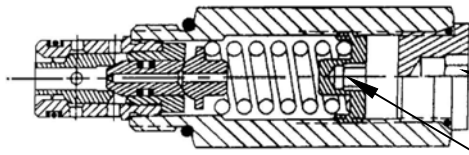

REMOVE CAP - ADJUST INTERNAL BOLT  
REPLACE CAP - PRIOR TO PRESSURIZING SYSTEM.

**DO NOT EXCEED 2000 PSI (136 BAR)**

TURN ADJUSTMENT:  
COUNTERCLOCKWISE TO DECREASE PRESSURE  
CLOCKWISE TO INCREASE PRESSURE.

---

---

## ADJUSTING SYSTEM PRESSURE

---

---

1. Release system pressure prior to servicing valve (See WARNING above).
2. Install a hydraulic pressure gauge (2 required) that is calibrated to 5000 psi (340 bar) using a short hose and tee to be in line with both the "open" and "close" ports of the main clamp valve.
3. Measure system pressure by deadheading the clamp in the closed position. System pressure is the difference between the pressure gauge reading of the "open" port subtracted from the pressure gauge reading of the "close" port.
4. Repeat step one if adjusting system pressure. Remove cap of the bi-directional relief valve (refer to item A page 7) and adjust cartridge no more than one quarter turn. Replace cap prior to pressurizing system. Repeat until desired pressure setting is achieved. Do not exceed 2000 psi (136 bar) in the system pressure.

---

---

## ADJUSTING BY-PASS PRESSURE

---

---

1. If one arm bottoms out before the other with more than 2" (51mm) difference adjustment is needed. Increase relief pressure (See above) if arms are moving independent of each other. If the lagging arm is moving slowly after first arm bottoms out, decrease relief pressure (See above).
2. To adjust by-pass relief pressure, release system pressure prior to servicing valve by turning the truck off and working the side shift and clamp function control several times.
3. Remove cap on bi-directional valve (item B page 7) and adjust cartridge no more than one quarter turn in needed direction. Replace cap prior to pressurizing system. Repeat adjustments until arms are in sync or within 2" (51mm) difference.
4. If assistance is needed in adjustments contact Loron LLC engineering.

---

---

# ARM SLIDE & SHIM REPLACEMENT

---

---

1. To replace the slides, the arms need to be in the fully open position. Release system pressure prior to removing the arms by turning the truck off and working the side shift and clamp function controls several times.
2. Support the arm with an overhead crane or lift truck. Be sure to secure the chain or sling in a manner that prevents the arm from falling out of the chain or sling when hanging free of the clamp.
3. Remove the cotter pin, slotted nut and spherical bearing from the end of the clamp cylinder rod. Keeping hands and feet clear, and carefully slide the clamp arm off of the clamp frame.
4. Inspect slides and slide buttons for wear. Slides may be rotated end-to-end and reused if excessively worn on the outer end only. Extra shims may be used to tighten operating clearance on slightly worn slides. Replace any slides worn to less than 0.15" (3.8mm) thick or any slide that is deeply scored or broken.

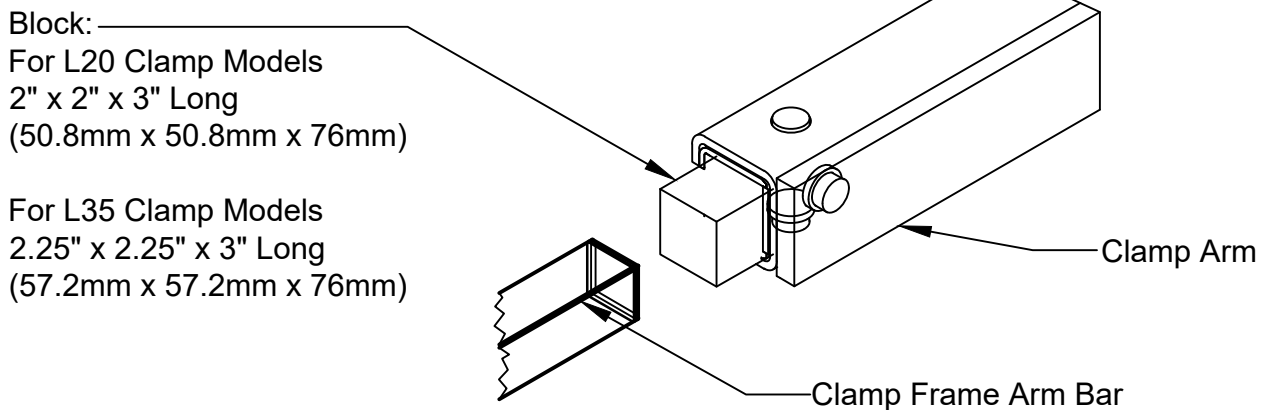

5. To aid in replacing the slides a block may be fashioned of wood or another convenient material to the dimensions shown above. The block is inserted to the end of the arm to hold the slides, shims, and buttons in position while the arm is inserted over the arm bars on the clamp frame. The block is expelled out the opposite end of the arm as the arm is pushed onto the frame. Prior to installing the arm the block may be used to determine the number of shims to place under the slides. Adjust the clearance between the slides and the block to provide approximately .06" (1.5mm) running clearance between the slides and arm when installed.
6. Keeping hands and feet clear, carefully slide the clamp arm onto the clamp frame. Be sure the arm moves freely without excessive binding. If the arm is too loose or too tight add or remove shims as required.
7. Install the spherical bearing, slotted nut and cotter pin onto the end of the clamp cylinder rod. Be sure to leave .03"-.06" (.7mm to 1.5mm) clearance to allow the cylinder to "float" on its mountings.

---

---

# TROUBLE SHOOTING GUIDE

---

---

## LOADS SLIPPING OR DROPPING

### POSSIBLE CAUSES

1. Valve cartridges are not sufficiently tight.
2. System relief pressure is set too low.
3. Internal leakage in cylinder.
4. Incorrect clamp pad size or load not fully engaged in clamp arms.
5. Pad camber is set incorrectly.
6. Load too heavy for clamp capacity.
7. Load may not be stacked correctly or may need to be unitized.
8. Bent arms or contact pads.

### SOLUTIONS

1. Tighten all cartridges to torque values shown on page 7.
2. See Adjusting System Pressure on page 8.
3. Replace Cylinder seals. If tube, piston or rod is scored replace with new parts.
4. Be sure the clamp pads are correctly sized for the load and the load is positioned fully in the clamp arms.
5. Shim pads to change camber.
6. Consult factory.
7. Re-stack or unitize load (shrink wrap).
8. Consult factory.

## CRUSHING LOADS

### POSSIBLE CAUSES

1. System relief pressure is set too high.
2. Operator over-working (milking) control valve.
3. Bent arms or contact pads.
4. Pad camber is set incorrectly.
5. Variable loads that require different clamping pressures.

### SOLUTIONS

1. See Adjusting System Pressure page 8.
2. Once the pad contacts the load, clamp the load in one even motion - do not over-work the valve.
3. Consult factory.
4. Shim pads to change the camber.
5. Install a 4-position pressure regulator on truck cowl - consult factory for part number and availability.